

Theory and Documentation

Weight and Balance Theory

Two elements are vital in the weight and balance considerations of an aircraft.

- The total weight of the aircraft must be no greater than the maximum weight allowed by the FAA for the particular make and model of the aircraft.
- The center of gravity, or the point at which all of the weight of the aircraft is considered to be concentrated, must be maintained within the allowable range for the operational weight of the aircraft.

Aircraft Arms, Weight, and Moments

The term arm, usually measured in inches, refers to the distance between the center of gravity of an item or object and the datum. Arms ahead of, or to the left of the datum are negative(-), and those behind, or to the right of the datum are positive(+). When the datum is ahead of the aircraft, all of the arms are positive and computational errors are minimized. Weight is normally measured in pounds. When weight is removed from an aircraft, it is negative(-), and when added, it is positive (+).

The manufacturer establishes the maximum weight and range allowed for the CG, as measured in inches from the reference plane called the datum. Some manufacturers specify this range as measured in percentage of the mean aerodynamic chord (MAC), the leading edge of which is located a specified distance from the datum.

The datum may be located anywhere the manufacturer chooses; it is often the leading edge of the wing or some specific distance from an easily identified location. One popular location for the datum is a specified distance forward of the aircraft, measured in inches from some point, such as the nose of the aircraft, or the leading edge of the wing, or the engine firewall.

The datum of some helicopters is the center of the rotor mast, but this location causes some arms to be positive and others negative. To simplify weight and balance computations, most modern helicopters, like airplanes,

have the datum located at the nose of the aircraft or a specified distance ahead of it.

A moment is a force that tries to cause rotation, and is the product of the arm, in inches, and the weight, in pounds. Moments are generally expressed in pound-inches (lb-in) and may be either positive or negative. Figure 2-1 shows the way the algebraic sign of a moment is derived. Positive moments cause an airplane to nose up, while negative moments cause it to nose down.

Weight	Arm	Moment	Rotation
+	+	+	Nose up
+	-	-	Nose down
-	+	-	Nose down
-	-	+	Nose up

Figure 2-1. Relationships between the algebraic signs of weight, arms, and moments.

The Law of the Lever

The weight and balance problems are based on the physical law of the lever. This law states that a lever is balanced when the weight on one side of the fulcrum multiplied by its arm is equal to the weight on the opposite side multiplied by its arm. In other words, the lever is balanced when the algebraic sum of the moments about the fulcrum is zero. [Figure 2-2] This is the condition in which the positive moments (those that try to rotate the lever clockwise) are equal to the negative moments (those that try to rotate it counter-clockwise).

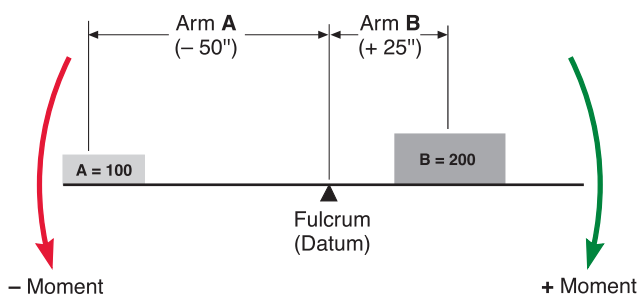

Figure 2-2. The lever is balanced when the algebraic sum of the moments is zero.

Consider these facts about the lever in Figure 2-2: The 100-pound weight A is located 50 inches to the left of the fulcrum (the datum, in this instance), and it has a moment of $100 \times 50 = -5,000$ in-lb. The 200-pound weight B is located 25 inches to the right of the fulcrum, and its moment is $200 \times 25 = +5000$ in-lb. The sum of the moment is $-5000 + 5000 = 0$, and the lever is balanced. [Figure 2-3] The forces that try to rotate it clockwise have the same magnitude as those that try to rotate it counterclockwise.

Item	Weight (lb)	Arm (in)	Moment (lb-in)
Weight A	100	-50	-5,000
Weight B	200	+25	+5,000
	300		0

Figure 2-3. When a lever is in balance, the sum of the moments is zero.

Determining the CG

One of the easiest ways to understand weight and balance is to consider a board with weights placed at various locations. We can determine the CG of the board and observe the way the CG changes as the weights are moved.

The CG of a board like the one in Figure 2-4 may be determined by using these four steps:

1. Measure the arm of each weight in inches from the datum.
2. Multiply each arm by its weight in pounds to determine the moment in pound-inches of each weight.
3. Determine the total of all weights and of all the moments. Disregard the weight of the board.
4. Divide the total moment by the total weight to determine the CG in inches from the datum.

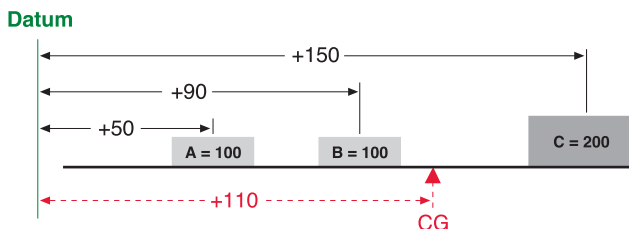

Figure 2-4. Determining the center of gravity from a datum located off the board.

In Figure 2-4, the board has three weights, and the datum is located 50 inches to the left of the CG of weight A. Determine the CG by making a chart like the one in Figure 2-5.

Item	Weight	Arm	Moment	CG
Weight A	100	50	5,000	
Weight B	100	90	9,000	
Weight C	200	150	30,000	
	400		44,000	110

Figure 2-5. Determining the CG of a board with three weights and the datum located off the board.

As noted in Figure 2-5, A weighs 100 pounds and is 50 inches from the datum; B weighs 100 pounds and is 90 inches from the datum; C weighs 200 pounds and is 150 inches from the datum. Thus the total of the three weights is 400 pounds, and the total moment is 44,000 lb-in.

Determine the CG by dividing the total moment by the total weight.

$$\begin{aligned}
 \text{CG} &= \frac{\text{Total moment}}{\text{Total weight}} \\
 &= \frac{44,000}{400} \\
 &= 110 \text{ inches from the datum}
 \end{aligned}$$

To prove this is the correct CG, move the datum to a location 110 to the right of the original datum and determine the arm of each weight from this new datum, as in Figure 2-6. Then make a new chart similar to the one in Figure 2-7. If the CG is correct, the sum of the moments will be zero.

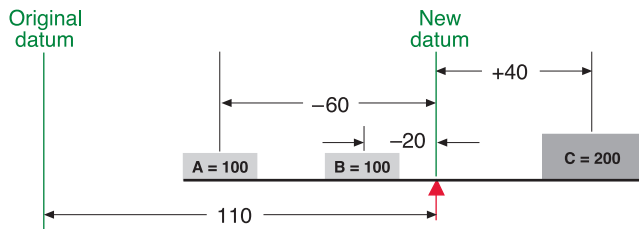

Figure 2-6. Arms from the datum assigned to the CG.

The new arm of weight A is 110 - 50 = 60 inches, and since this weight is to the left of the datum, its arm is negative, or -60 inches. The new arm of weight B is 110 - 90 = 20 inches, and it is also to the left of the datum, so it is -20; the new arm of weight C is 150 - 110 = 40 inches. It is to the right of the datum and is therefore positive.

Item	Weight	Arm	Moment
Weight A	100	-60	-6,000
Weight B	100	-20	-2,000
Weight C	200	+40	+8,000
			0

Figure 2-7. The board balances at a point 110 inches to the right of the original datum.

The board is balanced when the sum of the moments is zero. The location of the datum used for determining the arms of the weights is not important; it can be anywhere. But all of the measurements must be made from the same datum location.

Determining the CG of an airplane is done in the same way as determining the CG of the board in the previous example. [Figure 2-8] Prepare the airplane for weighing (as explained in Chapter 3) and place it on three scales. All tare weight, that is, the weight of any chocks or devices used to hold the aircraft on the scales, is subtracted from the scale reading, and the net weight from each wheel weigh point is entered on the chart like the one in Figure 2-9. The arms of the weighing points are specified in the Type Certificate Data Sheet (TCDS) for the airplane in terms of stations, which are distances in inches from the datum. Tare weight also includes items used to level the aircraft.

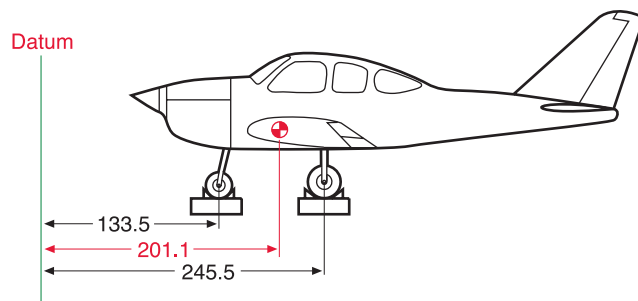

Figure 2-8. Determining the CG of an airplane whose datum is ahead of the airplane.

Item	Weight	Arm	Moment	CG
Main wheels	3,540	245.5	869,070	
Nose wheel	2,322	133.5	309,987	
Total	5,862		1,179,057	201.1

Figure 2-9. Chart for determining the CG of an airplane whose datum is ahead of the airplane.

The empty weight of this aircraft is 5,862 pounds. Its EWCG, determined by dividing the total moment by the total weight, is located at fuselage station 201.1. This is 201.1 inches behind the datum.

$$\begin{aligned}
 \text{CG} &= \frac{\text{Total moment}}{\text{Total weight}} \\
 &= \frac{1,179,057}{5,862} \\
 &= 201.1 \text{ inches behind the datum}
 \end{aligned}$$

Shifting the CG

One common weight and balance problem involves moving passengers from one seat to another or shifting baggage or cargo from one compartment to another to move the CG to a desired location. This also can be visualized by using a board with three weights and then working out the problem the way it is actually done on an airplane.

Solution by Chart

The CG of a board can be moved by shifting the weights as demonstrated in Figure 2-10. As the board is loaded, it balances at a point 72 inches from the CG of weight A. [Figure 2-11]

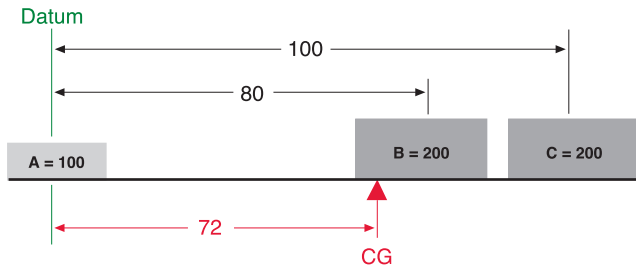

Figure 2-10. Moving the CG of a board by shifting the weights. This is the original configuration.

Item	Weight	Arm	Moment	CG
Weight A	100	0	0	
Weight B	200	80	16,000	
Weight C	200	100	20,000	
	500		36,000	72

Figure 2-11. Shifting the CG of a board by moving one of the weights. This is the original condition of the board.

To shift weight B so the board will balance about its center, 50 inches from the CG of weight A, first determine the arm of weight B that will produce a moment that causes the total moment of all three weights around this desired balance point to be zero. The combined moment of weights A and C around this new balance point, is 5,000 in-lb, so the moment of weight B will have to be -5,000 lb-in in order for the board to balance. [Figure 2-12]

Item	Weight	Arm	Moment
Weight A	100	-50	-5,000
Weight B			
Weight C	200	+50	+10,000
			+5,000

Figure 2-12. Determining the combined moment of weights A and C.

Determine the arm of weight B by dividing its moment, -5,000 lb-in, by its weight of 200 pounds. Its arm is -25 inches.

$$\begin{aligned} \text{Arm B} &= \frac{\text{Moment}}{\text{Weight}} \\ &= \frac{-5,000}{200} \\ &= -25 \end{aligned}$$

To balance the board at its center, weight B will have to be placed so its CG is 25 inches to the left of the center of the board, as in Figure 2-13.

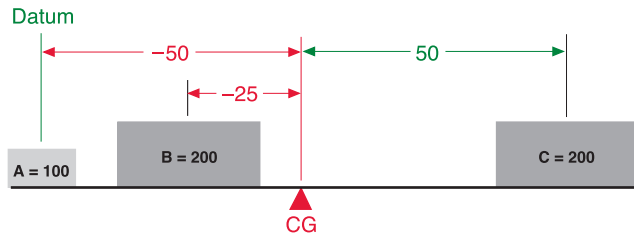

Figure 2-13. Placement of weight B to cause the board to balance about its center.

Basic Weight and Balance Equation

$$\frac{\text{Weight to be shifted}}{\text{Total weight}} = \frac{\Delta\text{CG}}{\text{Distance weight is shifted}}$$

This equation can be rearranged to find the distance a weight must be shifted to give a desired change in the CG location:

$$\text{Distance weight is shifted} = \frac{\text{Total weight} \times \Delta\text{CG}}{\text{Weight shifted}}$$

This equation can also be rearranged to find the amount of weight to shift to move the CG to a desired location:

$$\text{Weight shifted} = \frac{\text{Total weight} \times \Delta\text{CG}}{\text{Distance weight is shifted}}$$

It can also be rearranged to find the amount the CG is moved when a given amount of weight is shifted:

$$\Delta\text{CG} = \frac{\text{Weight shifted} \times \text{Distance weight is shifted}}{\text{Total weight}}$$

Finally, this equation can be rearranged to find the total weight that would allow shifting a given amount of weight to move the CG a given distance:

$$\text{Total weight} = \frac{\text{Weight shifted} \times \text{Distance weight is shifted}}{\Delta\text{CG}}$$

Solution by Formula

This same problem can also be solved by using this basic equation:

$$\frac{\text{Weight to be shifted}}{\text{Total weight}} = \frac{\Delta\text{CG}}{\text{Distance weight is shifted}}$$

Rearrange this formula to determine the distance weight B must be shifted:

$$\begin{aligned} \text{Distance weight B is shifted} &= \frac{\text{Total weight} \times \Delta\text{CG}}{\text{Weight shifted}} \\ &= \frac{500 \times -22}{200} \\ &= -55 \text{ inches} \end{aligned}$$

The CG of the board in Figure 2-10 was 72 inches from the datum. This CG can be shifted to the center of the board as in Figure 2-13 by moving weight B. If the 200-pound weight B is moved 55 inches to the left, the CG will shift from 72 inches to 50 inches, a distance of 22 inches. The sum of the moments about the new CG will be zero. [Figure 2-14]

Item	Weight	Arm	Moment
Weight A	100	-50	-5,000
Weight B	200	-25	-5,000
Weight C	200	+50	+10,000
			0

Figure 2-14. Proof that the board balances at its center. The board is balanced when the sum of the moments is zero.

When the distance the weight is to be shifted is known, the amount of weight to be shifted to move the CG to any location can be determined by another arrangement of the basic equation. Use the following arrangement of the formula to determine the amount of weight that will have to be shifted from station 80 to station 25, to move the CG from station 72 to station 50.

$$\begin{aligned} \text{Weight shifted} &= \frac{\text{Total weight} \times \Delta\text{CG}}{\text{Distance weight is shifted}} \\ &= \frac{500 \times 22}{55} \\ &= 200 \text{ pounds} \end{aligned}$$

If the 200-pound weight B is shifted from station 80 to station 25, the CG will move from station 72 to station 50.

A third arrangement of this basic equation may be used to determine the amount the CG is shifted when a given amount of weight is moved for a specified distance (as it was done in Figure 2-10). Use this formula to determine the amount the CG will be shifted when 200-pound weight B is moved from +80 to +25.

$$\begin{aligned} \Delta\text{CG} &= \frac{\text{Weight shifted} \times \text{Distance it is shifted}}{\text{Total weight}} \\ &= \frac{200 \times 55}{500} \\ &= 22 \text{ inches} \end{aligned}$$

Moving weight B from +80 to +25 will move the CG 22 inches, from its original location at +72 to its new location at +50 as seen in Figure 2-13.

Shifting the Airplane CG

The same procedures for shifting the CG by moving weights can be used to change the CG of an airplane by rearranging passengers or baggage.

Consider this airplane:

- Airplane empty weight and EWCG 1340 lbs @ +37.0
- Maximum gross weight 2,300 lbs
- CG limits..... +35.6 to +43.2
- Front seats (2) +35
- Rear seats (2) +72
- Fuel 40 gal @ +48
- Baggage (maximum) 60 lbs @ +92

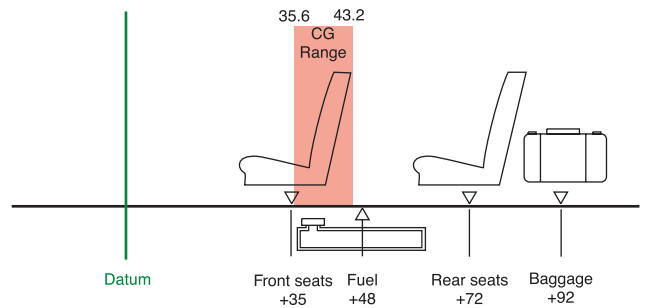

Figure 2-15. Loading diagram for a typical single-engine airplane.

The pilot has prepared a chart, Figure 2-16, with certain permanent data filled in and blanks left to be filled in with information on this particular flight.

Item	Weight 2,300 max	Arm	Moment	CG +35.6 to +43.2
Airplane	1,340	37	49,580	
Front Seats		35		
Rear Seats		72		
Fuel		48		
Baggage		92		

Figure 2-16. Blank loading chart.

For this flight, the 140-pound pilot and a 115-pound passenger are to occupy the front seats, and a 212-pound and a 97-pound passenger are in the rear seats. There will be 50 pounds of baggage, and the flight is to have maximum range, so maximum fuel is carried. The loading chart, Figure 2-17, is filled in using the information from Figure 2-15.

Item	Weight 2,300 max	Arm	Moment	CG +35.6 to +43.2
Airplane	1,340	37	49,580	
Front Seats	255	35	8,925	
Rear Seats	309	72	22,248	
Fuel	240	48	11,520	
Baggage	50	92	4,600	
	2,194		96,873	44.1

Figure 2-17. This completed loading chart shows the weight is within limits, but the CG is too far aft.

With this loading, the total weight is less than the maximum of 2,300 pounds and is within limits, but the CG is 0.9 inch too far aft.

One possible solution would be to trade places between the 212-pound rear-seat passenger and the 115-pound front-seat passenger. Use a modification of the basic weight and balance equation to determine the amount the CG will change when the passengers swap seats.

$$\begin{aligned} \Delta CG &= \frac{\text{Weight shifted} \times \text{Distance it is shifted}}{\text{Total weight}} \\ &= \frac{(212 - 115) \times (72 - 35)}{2,194} \\ &= \frac{97 \times 37}{2,194} \\ &= 1.6 \text{ inches} \end{aligned}$$

The two passengers changing seats moved the CG forward 1.6 inches, which places it within the operating range. This can be proven correct by making a new chart incorporating the changes. [Figure 2-18]

Item	Weight 2,300 max	Arm	Moment	CG +35.6 to +43.2
Airplane	1,340	37	49,580	
Front Seats	352	35	12,320	
Rear Seats	212	72	15,264	
Fuel	240	48	11,520	
Baggage	50	92	4,600	
	2,194		93,284	42.5

Figure 2-18. This loading chart, made after the seat changes, shows both the weight and balance are within allowable limits.

Weight and Balance Documentation

FAA-Furnished Information

Before an aircraft can be properly weighed and its empty-weight center of gravity computed, certain information must be known. This information is furnished by the FAA to anyone for every certificated aircraft in the Type Certificate Data Sheets (TCDS) or Aircraft Specifications and can be accessed via the internet at: www.faa.gov (home page), from that page, select “Regulations and Policies,” and at that page, select “Regulatory and Guidance Library.” This is the official FAA technical reference library.

When the design of an aircraft is approved by the FAA, an Approved Type Certificate and TCDS are issued. The TCDS includes all of the pertinent specifications for the aircraft, and at each annual or 100-hour inspection, it is the responsibility of the inspecting mechanic or repairman to ensure that the aircraft adheres to them. See pages 2-7 through 2-9, for examples of TCDS excerpts. A note about the TCDS: aircraft certificated before January 1, 1958, were issued Aircraft Specifications under the Civil Air Regulations (CARs), but when the Civil Aeronautical Administration (CAA) was replaced by the FAA, Aircraft Specifications were replaced by the Type Certificate Data Sheets. The weight and balance information on a TCDS includes the following:

Data Pertinent to Individual Models

This type of information is determined in the sections pertinent to each individual model:

CG Range

Normal Category
 (+82.0) to (+93.0) at 2,050 pounds.
 (+87.4) to (+93.0) at 2,450 pounds.

Utility Category

(+82.0) to (+86.5) at 1,950 pounds.
 Straight-line variations between points given.

Airspeed Limits	Never exceed	171 m.p.h. (148 knots) CAS
	Maximum Structural	140 m.p.h. (121 knots) CAS
	cruising	140 m.p.h. (121 knots) CAS
	Maneuvering	129 m.p.h. (112 knots) CAS
	Flaps extended	115 m.p.h. (100 knots) CAS

Center of Gravity Range (+84.0) to (+95.9) at 1650 lb. or less
 (+85.9) to (+95.9) at 1975 lb.
 (+88.2) to (+95.9) at 2200 lb.
 Straight line variation between points given

Empty Wt. C.G. Range None
Maximum Weight 2200 lb.
No. of Seats 4 (2 at +85.5, 2 at +118.1)
Maximum Baggage 125 lbs. (+142.8) (S/N 28-1 through 28-1760A)
 See NOTE 8.
 200 lbs. (+142.8) (S/N 28-1761 and up)

Fuel Capacity 50 gal. (2 wing tanks) (+95)
 See NOTE 1 for data on system fuel.

Oil Capacity 8 qts. (+32.5), 6 qts. useable
 See NOTE 1 for data on system oil.

Control Surface Movements	Wing flaps	(±2°)	Up	0°	Down	40°
	Ailerons	(±2°)	Up	30°	Down	15°
	Rudder	(±2°)	Left	27°	Right	27°
	Stabilator	(±2°)	Up	18°	Down	2°
	Stabilator tab	(±1°)	Up	3°	Down	12°

Nose Wheel Travel (+1°) Left 30° Right 30°
 (Effective on S/N 1 through 3377)
 Left 22° Right 22°
 (Effective on S/N 3378 and up)

Manufacturer's Serial Nos. 28-03, 28-1 and up.

II. Model PA-28-150, Cherokee, 4 PCLM (Normal Category), Approved June 2, 1961

Engine Lycoming O-320-A2B or O-320-E2A with carburetor setting 10-3678-32
Fuel 80/87 minimum grade aviation gasoline
Engine Limits For all operations, 2700 r.p.m. (150 h.p.)

Propeller and Propeller Limits Sensenich M74DM or 74DM6 on S/N 1 through 1760A;
 Sensenich M74DMS or 74DM6S5 on S/N 1761 and up
 Static r.p.m. at maximum permissible throttle setting not over 2375, not under 2275.
 No additional tolerance permitted.
 Diameter: Not over 74", not under 72.5."
 See NOTE 10.

Figure 2-19. Excerpts for a Type Certificate Data Sheet (continued)

Data Pertinent to All Models:

Datum	78.4" forward of wing leading edge (straight wing only). 78.4" forward of inboard intersection of straight and tapered sections (semi-tapered wings).
Leveling Means	Two screws left side fuselage below window.
Certification Basis	<p>Type Certificate No. 2A13 issued October 31, 1960. Date of Application for Type Certificate, February 14, 1965.</p> <p>Delegation Option Authorization granted per FAR 21, Subpart J. July 17, 1968.</p> <p>PA-28-140 and PA-28-151: CAR 3, effective May 15, 1956, including Amendments 3-1, 3-2, 3-4, and paragraphs 3.304 and 3.705 of Amendment 3-7.</p> <p>PA-28-150, PA-28-160, PA-28-180, PA-28-235, PA-28S-160, PA-28S-180, PA-28R-180, PA-28R-200; CAR 3, effective May 15, 1956, including Amendments 3-1, 3-2 and paragraphs 3.304 and 3.705.</p> <p>PA-28-161: CAR 3 effective May 15, 1956, through Amendment 3-2; paragraph 3.387(d) of Amendment 3-4; paragraphs 3.304 and 3.705 of Amendment 3-7; FAR 23.959 of Amendment 23-7; FAR 36 effective December 1, 1969, through Amendment 36-4.</p> <p>PA-28-181: CAR 3 effective May 15, 1956, through Amendment 3-2, Amendment 3-4 and paragraphs 3.304 and 3.705 of Amendment 3-7. Also, FAR 23.207, 23.221 and 23.959 of Amendment 23-7.</p> <p>PA-28R-201: CAR 3 effective May 15, 1956, through Amendment 3-2; paragraphs 3.304 and 3.705 of Amendment 3-7; paragraphs 23.221, 23.959, 23.965, 23.967(e)(2), 23.1091 and 23.1093 of FAR 23 Amendment 23-16; FAR 36 effective December 1, 1969, through Amendment 36-4 (no acoustical change).</p> <p>PA-28R-201T: CAR 3 effective May 15, 1956, through Amendment 3-2 including paragraphs 3.304 and 3.705 of Amendment 3-7; FAR 23.221, 23.901, 23.909, 23.959, 23.965, 23.967(e)(2), 23.1041, 23.1043, 23.1047, 23.1143, 23.1305, 23.1441 and 23.1527 of Amendment 23-16; FAR 36 effective December 1, 1969, through Amendment 36-4.</p> <p>PA-28-236: CAR 3 effective May 15, 1956, through Amendment 3-2, and paragraphs 3.304 and 3.705 of Amendment 3-7 effective May 3, 1962. FAR 23.221, 23.959, 23.1091, and 23.1093 of FAR Part 23, Amendment 23-17 effective February 1, 1977; FAR 23.1581(b)(2) of FAR 23 Amendment 23-21 effective March 1, 1978; and applicable portions of FAR 36, as amended up to Amendment 36-9 effective April 3, 1978.</p>

Figure 2-19. Excerpts for a Type Certificate Data Sheet (continued)

If this information is given, there may be a chart on the TCDS similar to the one in Figure 2-20. This chart helps visualize the CG range. Draw a line horizontally from the aircraft weight and a line vertically from the fuselage station on which the CG is located. If these lines cross inside the enclosed area, the CG is within the allowable range for the weight.

Note that there are two enclosed areas: the larger is the CG range when operating in the Normal category only, and the smaller range is for operating in both the Normal and Utility categories. When operating with the weight and CG limitations shown for Utility category, the aircraft is approved for limited acrobatics such as spins, lazy eights, chandelles, and steep turns in which the bank angle exceeds 60°. When operating outside of the smaller enclosure but within the larger, the aircraft is restricted from these maneuvers.

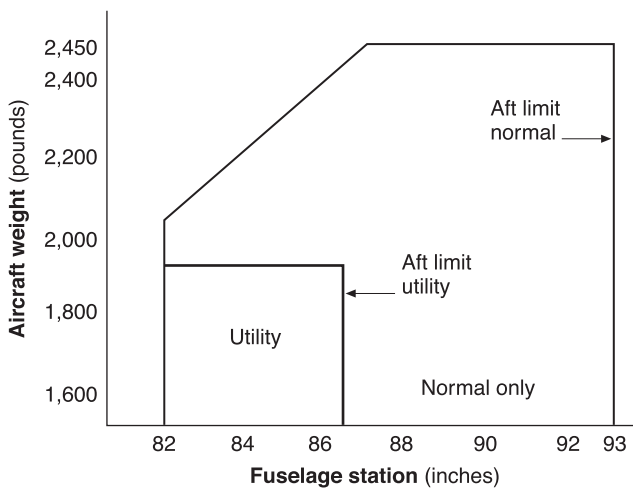

Figure 2-20. CG range chart.

If the aircraft has retractable landing gear, a note may be added, for example:

“Moment due to retracting of landing gear (+819 lb-in).”

Empty Weight CG Range

When all of the seats and baggage compartments are located close together, it is not possible, as long as the EWCG is located within the EWCG range, to legally load the aircraft so that its operational CG falls outside this allowable range. If the seats and baggage areas extend over a wide range, the EWCG range will be listed as “None.”

Maximum Weights

The maximum allowable takeoff and landing weights and the maximum allowable ramp weight are given. This basic information may be altered by a note, such as the following:

“NOTE 5. A landing weight of 6,435 lbs must be observed if 10 PR tires are installed on aircraft not equipped with 60-810012-15 (LH) or 60-810012-16 (RH) shock struts.”

Number of Seats

The number of seats and their arms are given in such terms as:

“4 (2 at +141, 2 at +173)”

Maximum Baggage (Structural Limit)

This is given as:

“500 lbs at +75 (nose compartment)
655 lbs at +212 (aft area of cabin)”

Fuel Capacity

This important information is given in such terms as:

“142 gal (+138) comprising two interconnected cells in each wing”

-or-

“204 gal (+139) comprising three cells in each wing and one cell in each nacelle (four cells interconnected) See NOTE 1 for data on fuel system.”

“NOTE 1” will read similar to the following example:

“NOTE 1. Current weight and balance data, including list of equipment included in standard empty weight and loading instructions when necessary, must be provided for each aircraft at the time of original certification.

The standard empty weight and corresponding center of gravity locations must include unusable fuel of 24 lbs at (+135).”

Oil Capacity (Wet Sump)

The quantity of the full oil supply and its arm are given in such terms as:

“26 qt (+88)”

Data Pertinent to all Models

Datum

The location of the datum may be described, for example, as:

“Front face of firewall”

-or-

78.4 inches forward of wing leading edge (straight wing only).

78.4 inches forward of inboard intersection of straight and tapered sections (semi-tapered wings).

Leveling Means

A typical method is:

“Upper door sill.”

This means that a spirit level is held against the upper door sill and the aircraft is level when the bubble is centered. Other methods require a spirit level to be placed across leveling screws or leveling lugs in the primary aircraft structure or dropping a plumbline between specified leveling points.

TCDS are issued for aircraft that have been certificated since January 1, 1958, when the FAA came into being. For aircraft certificated before this date, basically the same data is included in Aircraft, Engine, or Propeller Specifications that were issued by the Civil Aeronautics Administration.

Within the Type Certificate Data Sheets, Specifications, and Listings, Volume VI, titled “The Aircraft Listings” includes weight and balance information on aircraft of which there are fewer than 50 listed as being certificated.

Manufacturer-Furnished Information

When an aircraft is initially certificated, its empty weight and EWCG are determined and recorded in the weight and balance record such as the one in Figure 2-21. Notice in this figure that the moment is expressed as “Moment (lb-

in/1000).” This is a moment index which means that the moment, a very large number, has been divided by 1,000 to make it more manageable. Chapter 4 discusses moment indexes in more detail.

An equipment list is furnished with the aircraft, which specifies all the required equipment, and all equipment approved for installation in the aircraft. The weight and arm of each item is included on the list, and all equipment installed when the aircraft left the factory is checked.

When an aircraft mechanic or repairman adds or removes any item on the equipment list, he or she must change the weight and balance record to indicate the new empty weight and EWCG, and the equipment list is revised to show which equipment is actually installed. Figure 2-22 is an excerpt from a comprehensive equipment list that includes all of the items of equipment approved for this particular model of aircraft. The POH for each individual aircraft includes an aircraft specific equipment list of the items from this master list. When any item is added to or removed from the aircraft, its weight and arm are determined in the equipment list and used to update the weight and balance record.

The POH/AFM also contains CG moment envelopes and loading graphs. Examples of the use of these handy graphs are given in chapter 4.

Weight and Balance Data

Aircraft Serial No. 18259080

F.A.A. Registration No. N42565

Date: 4-22-05

Item	Weight (lbs) X	C.G. Arm (in) =	Moment (lb-in)
Standard empty weight	1,876	36.1	67,798.6
Optional equipment	1.2	13.9	16.7
Special installation	6.2	41.5	257.3
Paint	—	—	—
Unusable fuel	30.0	46.0	1,380
Basic empty weight	1,913.4		69,452.6

Figure 2-21. Typical weight and balance data for 14 CFR part 23 airplane.

Comprehensive Equipment List

The following figure (Figure 6-9) is a comprehensive list of all Cessna equipment which is available for the Model 182S airplane. It should not be confused with the airplane-specific equipment list. An airplane-specific list is provided with each individual airplane at delivery, and is typically inserted at the rear of this Pilot's Operating Handbook. The following comprehensive equipment list and the airplane-specific list have a similar order of listing.

The comprehensive equipment list provides the following information in column form:

In the **Item No** column, each item is assigned a coded number. The first two digits of the code represent the assignment of item within the ATA Specification 100 breakdown (Chapter 11 for Placards, Chapter 21 for Air Conditioning, Chapter 77 for Engine Indicating, etc...). These assignments also correspond to the Maintenance Manual chapter breakdown for the airplane. After the first two digits (and hyphen), items receive a unique sequence number (01, 02, 03, etc...). After the sequence number (and hyphen), a suffix letter is assigned to identify equipment as a required item, a standard item or an optional item. Suffix letters are as follows:

- R = required items or equipment for FAA certification
- S = standard equipment items
- O = optional equipment items replacing required or standard items
- A = optional equipment items which are in addition to required or standard items

In the **Equipment List Description** column, each item is assigned a descriptive name to help identify its function.

In the **Ref Drawing** column, a drawing number is provided which corresponds to the item.

Note

If additional equipment is to be installed, it must be done in accordance with the reference drawing, service bulletin or a separate FAA approval.

In the **Wt Lbs** and **Arm Ins** columns, information is provided on the weight (in pounds) and arm (in inches) of the equipment item.

Notes

Unless otherwise indicated, true values (not net change values) for the weight and arm are shown. Positive arms are distances aft of the airplane datum; negative arms are distances forward of the datum.

Asterisks (*) in the weight and arm column indicate complete assembly installations. Some major components of the assembly are listed on the lines immediately following. The sum of these major components does not necessarily equal the complete assembly installation.

Figure 2-22. Excerpt from a typical comprehensive equipment list.

Item No	Equipment List Description	Ref Drawing	Wt (lbs.)	Arm (ins.)
24-04-S	Basic Avionics Kit Installation - Support Straps Installation - Avionics Cooling Fan Installation - Avionics Ground Installations - Circuit Breaker Panel Installation - Microphone Installation - Omni Antenna Installation - Omni Antenna Cable Assembly Installation		4.3* 0.1 1.6 0.1 1.5 0.2 0.5 0.3	55.5* 10.0 3.0 41.0 16.5 18.5 252.1 248.0
Chapter 25 – Equipment/Furnishings				
25-01-R	Seat, Pilot, Adjustable		33.8	41.5
25-02-S	Seat, Copilot, Adjustment		33.8	41.5
25-03-S	Seat, Rear, Two Piece Back Cushion		50.0	82.0
25-04-R	Seat Belt and Shoulder Harness, Inertia Reel, Pilot and Copilot		5.2	50.3
25-05-S	Seat Belt and Shoulder Harness, Inertia Reel, Rear Seat		5.2	87.8
25-06-S	Sun Visors (Set of 2)		1.2	33.0
25-07-S	Baggage Retaining Net		0.5	108.0
25-08-S	Cargo Tie Down Rings (10 Tie Downs)		0.4	108.0
25-09-S	Pilot's Operating Checklist (Stowed in Instrument Panel Map Case)		0.3	15.0
25-10-R	Pilot's Operating Handbook and FAA Approved Airplane Flight Manual (Stowed in Pilot's Seat Back)		1.2	61.5
25-11-S	Fuel Sampling Cup		0.1	14.3
25-12-S	Tow Bar, Nose Gear (Stowed)		1.7	108.0
25-13-S	Emergency Locator Transmitter Installation - ELT Transmitter - Antenna and Cable Assembly - Hardware		2.2* 1.7 0.4 0.1	134.8* 135.0 133.0 138.0
Chapter 26 – Fire Protection				
26-01-S	Fire Extinguisher Installation - Fire Extinguisher - Mounting Clamp & Hardware		5.3* 4.8 0.5	29.0* 29.0 29.0
Chapter 27 – Flight Controls				
27-01-S	Dual Controls Installation, Right Seat - Control Wheel, Copilot - Rudder and Brake Pedal Installation Copilot		6.3* 2.0 4.3	12.9* 26.0 6.8

Figure 2-22. Excerpt from a typical comprehensive equipment list (continued).

